



FUTURE-FOCUSED EQUIPMENT

VC70
Vacuum crawler



- Powerful
- Proven in practice
- Ergonomic
- Eco-friendly
- Future-focused

www.streicher-ecotec.de



PROGRESS IN EFFICIENCY AND ERGONOMIC OPERABILITY

OVERVIEW OF VC70

Efficiency, occupational safety, environmental protection and ergonomics are core key issues on construction sites. In order to make the removal of a wide variety of soil materials more efficient and less damaging to people and the environment, STREICHER has developed the vacuum crawler VC70. The vacuum crawler is applicable for various purposes, to quickly uncover tree roots, plants and interred line conduits without damaging them, as well as for cleaning industrial plants and sewage systems.

In addition, the new vacuum crawler combines numerous additional advantages in its varied areas of use:

- The remote-controlled vacuum crawler can be prominently used for vacuuming **non-cohesive soils such as earth, sand, gravel and stones**. Also **mud and water** can be conveniently suctioned off with the VC70.
- With its **compact size** and its **flexible maneuverability**, the vacuum crawler can easily pass through narrow access points. It can also be driven on pavements and eliminates the need for road closures.

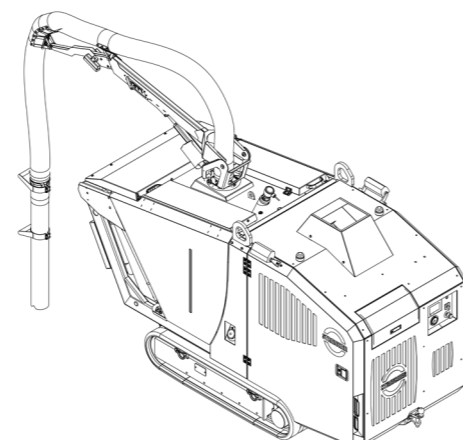
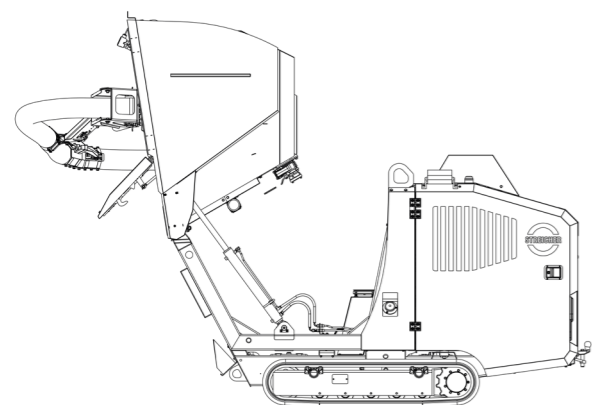
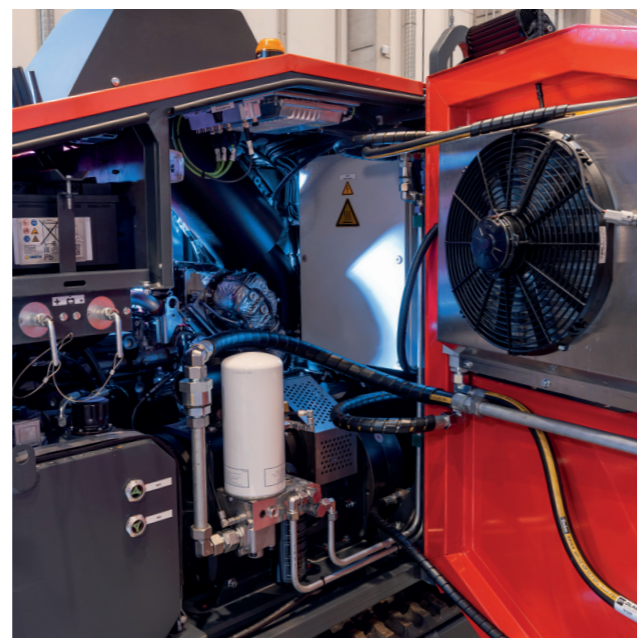

- The VC70 can be transported on a conventional 3.5 t trailer due to its low transportation weight. Its practical mounted attachment points also allow for it being lifted by a crane.
- The VC70 also impresses with its high rate of **efficiency**. An automatic vacuuming function provides a more efficient operability for excavation activities compared to manual excavation. Likewise **ergonomic work** is made possible and a gentle operation process is guaranteed.
- In terms of **safety**, the VC70 vacuum crawler impresses with its integrated tilt sensor among other things. An early warning of steep sloped terrains is relayed to the operator by visual and acoustic warning signals.
- The VC70 is operated via a **radio remote control**. Its suction operation can be intuitively operated by a radio remote control at the convenience of an infinitely variable vacuuming power performance. A choice between two gears allows the unit's operative maneuverability to be optimally adjusted to its running terrain. Because of the radio remote control an optimal field of vision is ensured and therefore the risk of accidents is reduced.
- What makes the VC70 unique is the powerful **integrable compressor**. The compressor can be optimally integrated into the vacuum crawler, resulting in considerable transport efficiency. This makes the compressor usable also as a single-standing element for an operation with other tools.

The VC70 combines its proven technology with highest standards in efficiency, ergonomic operability and its protection of the environment.





**INNOVATIVE AND
FUTURE-FOCUSED**

**POWERFUL, ERGONOMIC AND GENTLE IN USE.
OUR VACUUM CRAWLERS WILL IMPRESS WITH THEIR
FLEXIBLE AND VERSATILE POSSIBILITIES OF OPERATION.**

